

NARROW AISLE

Narrow Aisle Reach and Straddle Trucks Electric 24 or 36 Volt

NPR15D	3,000 lbs 1350 kg
NPR17	3,500 lbs 1600 kg
NPR20	4,000 lbs 1800 kg
NPR22/NSR22	4,500 lbs 2000 kg
NSR25	5,000 lbs 2275 kg

NPR15D/17
20/22
NSR22/25



For corresponding data see Specification Chart.

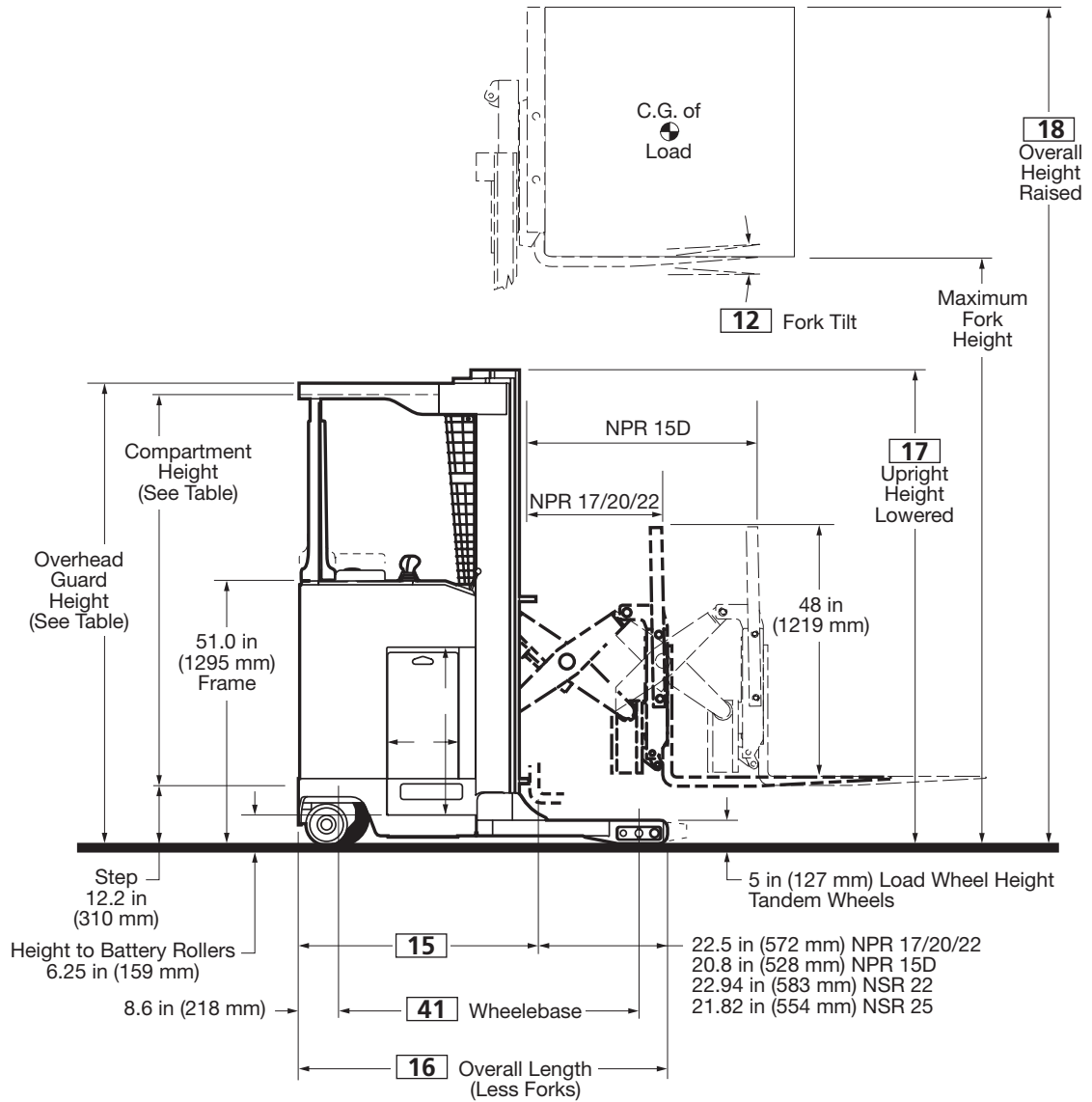

NPR15D/17/20/22 NSR22/25

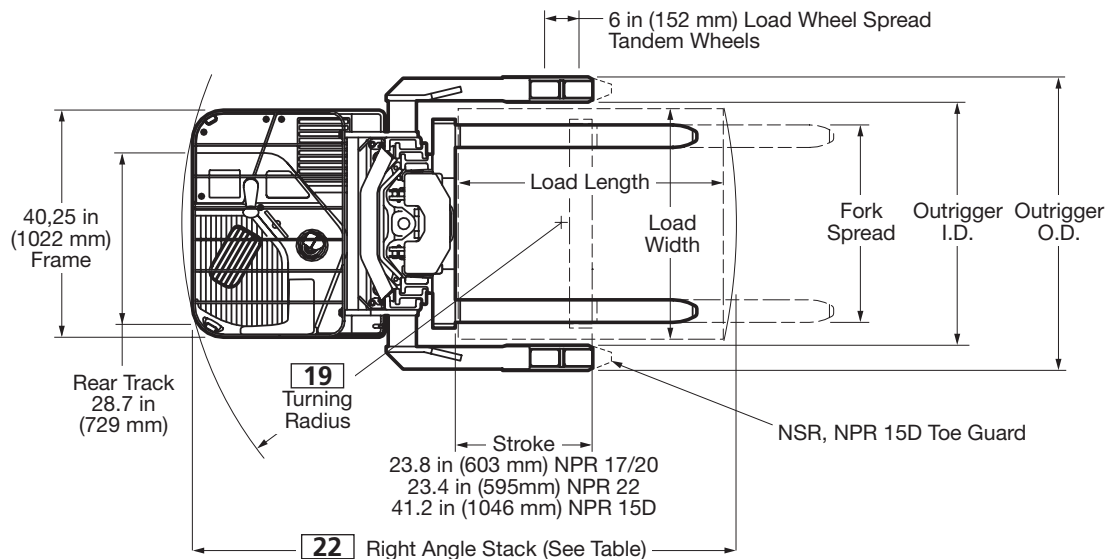

Upright Table

Maximum Fork Height		Overall Height Lowered		Free Lift	
in	mm	in	mm	in	mm
198	5029	89	2261	54	1372
210	5334	95	2413	60	1524
240	6096	107	2718	72	1829
258	6553	113	2870	78	1981
270	6858	119	3023	84	2134
300	7620	131	3327	96	2438
318	8077	139	3531	104	2642
• 321	8153	139	3531	104	2642
• 330	8382	149	3785	114	2896
• 366	9296	161	4089	126	3200

For overall height raised with load backrest, add 48 in (1219 mm) to maximum fork height. Other uprights available, contact Clark representative. Uprights above 270" n/a on NPR17, above 318 n/a on NPR20.

- NPR 15D, NPR 22, NSR 25 only.

Carriage Widths*/Fork Spread in(mm)

Carriage Width		Fork Spread w/o Side Shifter		Fork Spread w/ Side Shifter	
in	mm	max	min	max	min
33	838	31.0(787)	13.0(330)	27.7(704)	22.3(566)
37	940	35.0(889)	13.0(330)	27.7(704)	22.3(566)

* 37 in. wide carriages only available with outrigger I.D. 38 in. and greater (40 in. and greater with 10.5 in. load wheels).

NPR Min. Right Angle Stack Aisle in(mm)*

Pallet or Load Size Length x Width	Battery Compartment (L)			
	13.88(353)	16.13(410)	18.5(470)**	21.0(533)**
36x30(914x762)	82.2(2088)	84.1(2136)	86.8(2205)	89.0(2261)
42x36(1067x914)	87.1(2212)	89.2(2266)	92.1(2339)	94.5(2400)
36x40(914x1016)	82.0(2083)	83.9(2131)	86.8(2205)	89.0(2261)
40x40(1016x1016)	84.8(2154)	86.8(2205)	89.6(2276)	91.9(2334)
48x40(1219x1016)	93.0(2362)	95.1(2416)	98.2(2494)	100.6(2555)
48x42(1219x1067)	92.8(2357)	94.9(2410)	98.0(2489)	100.4(2550)
48x44(1219x1118)	92.6(2352)	94.7(2405)	97.7(2482)	100.2(2545)
48x48(1219x1219)	92.2(2342)	94.3(2395)	97.3(2471)	99.8(2535)

* Add 6 to 8 inches clearance for ease of operation. Dimensions are based on 42 inch I.D. outrigger with 5 x 3.76 in. load wheels and 4" clearance each side of load.

** Add 8" for NPR 15D (plus operating clearance).

NSR Min. Right Angle Stack Aisle in(mm)*

Pallet or Load Size Length x Width	Battery Compartment (L)			
	13.88(353)	16.13(410)	18.5(470)	21.0(533)
36x30(914x762)	79.7(2024)	81.6(2073)	86.1(2187)	88.3(2243)
42x36(1067x914)	82.3(2090)	84.3(2141)	87.6(2225)	89.8(2281)
36x40(914x1016)	82.0(2083)	83.9(2131)	88.2(2240)	90.4(2296)
40x40(1016x1016)	82.0(2083)	83.9(2131)	88.2(2240)	90.4(2296)
48x40(1219x1016)	89.5(2273)	91.6(2327)	95.1(2416)	97.4(2474)
48x42(1219x1067)	89.1(2263)	91.2(2316)	94.7(2405)	97.1(2466)
48x44(1219x1118)	88.8(2256)	90.9(2309)	94.4(2398)	96.7(2456)
48x48(1219x1219)	88.3(2243)	90.4(2296)	94.0(2388)	96.0(2438)

* Add 6 to 8 inches clearance for ease of operation. Dimensions are based on I.D. 2" wider than load, 5 x 3.76 load wheels and 7" clearance each side of load.

Grade Clearance

Battery Compartment Width in(mm)	A%
13.38(340), 13.88(353)	15.0%
16.13(410)	14.5%
18.5(470)	11.6%
21.0(533)	10.9%

Outrigger Dimensions - I.D./O.D. (in)

Dual 5 x 3.76 Load Wheels Toe Box Width 5.5 in I.D. O.D.		Dual 5 x 3.01 Load Wheels Toe Box Width 4.5 in I.D. O.D.		Single 10.5 x 4.5 Load Wheels Toe Box Width 6.0 in I.D. O.D.		Dual 4 x 2.62 Load Wheels Toe Box Width 4.5 in I.D. O.D.	
33	44	33	42	-	-	33	42
34	45	34	43	-	-	34	43
36	47	35	44	36.25	48.25	35	44
38	49	37	46	38.25	50.25	37	46
40	51	39	48	40.25	52.25	39	48
41	52	41	50	41.25	53.25	41	50
42	53	42	51	42.25	54.25	42	51
44	55	43	52	44.25	56.25	43	52
46	57	45	54	46.25	58.25	45	54
48	59	47	56	48.25	60.25	47	56
50	61	49	58	50.25	62.25	49	58
-	-	51	60	-	-	51	60

Outrigger Dimensions - I.D./O.D. (mm)

Dual 127 x 96 Load Wheels Toe Box Width 140mm I.D. O.D.		Dual 127 x 76 Load Wheels Toe Box Width 114mm I.D. O.D.		Single 267 x 114 Load Wheels Toe Box Width 152mm I.D. O.D.		Dual 102 x 67 Load Wheels Toe Box Width 114mm I.D. O.D.	
838	1118	838	1067	-	-	838	1067
864	1143	864	1092	-	-	864	1092
914	1194	889	1118	921	1226	889	1118
965	1245	940	1168	972	1276	940	1168
1016	1295	991	1219	1022	1327	991	1219
1041	1321	1041	1270	1048	1353	1041	1270
1067	1346	1067	1295	1073	1378	1067	1295
1118	1397	1092	1321	1124	1429	1092	1321
1168	1448	1143	1372	1175	1480	1143	1372
1219	1499	1194	1422	1226	1530	1194	1422
1270	1549	1245	1473	1276	1581	1245	1473
-	-	1295	1524	-	-	1295	1524

Battery Compartment Dimensions

Width (W)		Length (L)		Height (H)	
in	mm	in	mm	in	mm
38.75	984	13.38	340	32.0	813
38.75	984	13.88	353	32.0	813
38.75	984	16.13	410	32.0	813
38.75	984	18.50	470	32.0	813
38.75	984	21.00	533	32.0	813

Maximum Battery Size

Width (W)		Length (L)		Height (H)	
in	mm	in	mm	in	mm
38.69	983	13.00	330	31.5	800
38.69	983	13.50	343	31.5	800
38.69	983	15.75	400	31.5	800
38.69	983	18.00	457	31.5	800
38.69	983	20.50	521	31.5	800

Operator Compartment/ Overhead Guard Dimensions

Maximum Fork Height		Compartment Inside		Overhead Guard Height	
in	mm	in	mm	in	mm
198	5029	75	1905	89	2261
210	5334	81	2057	95	2413
240	6096	81	2057	95	2413
258	6553	81	2057	95	2413
270	6858	81	2057	95	2413
300	7620	81	2057	95	2413
318	8077	81	2057	95	2413
* 321	8153	81	2057	95	2413
* 330	8382	81	2057	95	2413
* 366	9296	81	2057	95	2413

*NPR 15D, NPR 22, NSR25 only.

General Information	1	Manufacturer		Clark	Clark	
	2	Model	Manufacturer's Designation	NPR17	NPR20	
	3	Load Capacity		lbs(kg)	3500 (1600)	4000 (1800)
	4	Load Center	Fork Face to Load CG	in(mm)	24 (600)	24 (600)
	5	Power Unit	Type		24 volt 36 volt	24 volt 36 volt
	6	Operator Type			Rider Reach	Rider Reach
	7	Tire Type			Solid	Solid
	8	Wheels (x=driven)	Front/Rear		4/2 (1x)	4/2 (1x)
Basic Dimensions ^{1,2}	10	Upright ³	Lift height (data for 210 in MFH upright)	in(mm)	210 (5334)	210 (5334)
	11		Free Lift	in(mm)	60 (1524)	60 (1524)
	12	Fork Tilt	Back/Forward	degrees	4 / 3	4 / 3
	14	Fork	Std. Fork Size (T x W x L)	in(mm)	1.75 x 4 x 42 (44 x 102 x 1067)	1.75 x 4 x 42 (44 x 102 x 1067)
	15	Overall Dimensions	Length to Fork Face	in(mm)	48.1 (1222)	48.1 (1222)
	16		Overall Length, less forks	in(mm)	70.25 (1784)	70.25 (1784)
			Outrigger ID/OD	in(mm)	See Outrigger Dimensions Chart	See Outrigger Dimensions Chart
			Frame Width	in(mm)	40.25 (1022)	40.25 (1022)
	17		Height, Upright Lowered	in(mm)	95 (2413)	95 (2413)
	18		Height, Upright Extended	in(mm)	258 (6553)	258 (6553)
	19	Turning Radius		in(mm)	66.5 (1689)	66.5 (1689)
22	Right Angle Stack Aisle ⁴	48 in x 40 in pallet	in(mm)	93.0 (2362)	93.0 (2362)	
	Battery Compartment	W x L x H	in(mm)	38.75 x 13.88 x 32 (984 x 353 x 813)	38.75 x 13.88 x 32(984 x 353 x 813)	
Performance	23	Stability	According to ANSI		Yes	Yes
	24	Speeds	Travel Speed, Max w/ Load	mph(kph)	5.8 (9.3) 6.7 (10.8)	5.7 (9.2) 6.6 (10.6)
	25		Travel Speed, Max w/o Load	mph(kph)	6.3 (10.1) 7.2 (11.6)	6.3 (10.1) 7.2 (11.6)
	26		Lift Speed, with Load ⁵	fpm(ms)	42 (.21) 62 (.31)	40 (.20) 60 (.30)
	27		Lift Speed, without Load ⁵	fpm(ms)	65 (.33) 95 (.48)	65 (.33) 95 (.48)
	28		Lower Speed, with Load	fpm(ms)	80 (.41)	80 (.41)
	29		Lower Speed, without Load	fpm(ms)	90 (.46)	90 (.46)
Weights	34	Service weight	Including battery, less load	lbs(kg)	6660 (3024)	6940 (3151)
	35	Axle loading	With Load, Front	lbs(kg)	6390 (2901)	7030 (3192)
	36		With Load, Rear	lbs(kg)	3770 (1712)	3910 (1775)
	37		W/O Load, Front	lbs(kg)	2445 (1110)	2520 (1144)
	38		W/O Load, Rear	lbs(kg)	4215 (1914)	4420 (2007)
Chassis	39	Tires/Wheels	Number, Front/Rear		4 / 2	4 / 2
	40		Size, Load Wheels	in(mm)	(4) 5 x 3.76 urethane (127 x 96)	(4) 5 x 3.76 urethane(127 x 96)
			Size, Rear Drive/Steer	in(mm)	13.5 x 5.5 rubber (343 x 140)	13.5 x 5.5 rubber (343 x 140)
			Size, Rear Caster	in(mm)	8 x 4 urethane (203 x 102)	8 x 4 urethane (203 x 102)
	41	Wheelbase		in(mm)	56.1 (1425)	56.1 (1425)
	44	Ground Clearance	With 5.0 diameter load wheels	in(mm)	1.75 (44)	1.75 (44)
	46	Service Brake	Type		Drum and Shoe	Drum and Shoe
	47	Parking Brake	Type		Automatic, Spring Applied	Automatic, Spring Applied
	Steering	Type		Hydraulic Assist, variable	Hydraulic Assist, variable	
Drive Line	48	Battery	Type		Lead Acid	Lead Acid
			Capacity (6 hr rate) maximum	kWh	28.9 27.0	28.9 27.0
			Weight, minimum	lbs(kg)	1590 (722)	1590 (722)
	49	Motors, Controls	Drive Motor, diameter	in(mm)	6.7 (170)	6.7 (170)
			Hydraulic Motor, diameter	in(mm)	8.0 (203)	8.0 (203)
			Steer/Auxiliary Motor, diameter	in(mm)	6.4 (163)	6.4 (163)
			Drive Motor control	Type	Transistor, infinite	Transistor, infinite
			Speed control	Type	Solid state	Solid state
			Hydraulic Motor control	Type	Contactorm	Contactorm
		Steer/Auxiliary Motor control	Type	Transistor, infinite	Transistor, infinite	

Notes:

- Specifications are for tandem 5 in (127 mm) diameter x 3.76 in (96mm) wide load wheels. Single 10.5 in (267 mm) diameter x 4.5 in (114 mm) load wheels and tandem 5 in (127 mm) diameter x 3.01 in (76 mm) wheels are also available.
- Specifications are given for truck with 210 in (5334 mm) MFH upright, and 42 in (1067 mm) outrigger I.D. and 37 in (940 mm) sidershifter (deduct 50 lbs. (23 kg) for weight less sidershifter). Battery compartment dimensions as noted.

- See Upright Table. Contact Clark Representative for additional lift heights.
- Right angle stacking aisle for pallet size shown. See "General Data" section for right angle stack aisle with other pallet sizes.
- High speed lift is standard on NPR 22 and 15D with 18.5 in (470 mm) and 21.0 in (533 mm) battery compartments; lift speeds will reduce when 16.13 in (409.7 mm) compartment is used.

General Information	1	Manufacturer		Clark	Clark	
	2	Model	Manufacturer's Designation	NPR22	NPR15D	
	3	Load Capacity	lbs(kg)	4500 (2000)	3000 (1350)	
	4	Load Center	Fork Face to Load CG	in(mm)	24 (600)	24 (600)
	5	Power Unit	Type	36 volt	36 volt	
	6	Operator Type		Rider Reach	Rider Double Reach	
	7	Tire Type		Solid	Solid	
	8	Wheels (x=driven)	Front/Rear	4/2 (1x)	4/2 (1x)	
Basic Dimensions ^{1,2}	10	Upright ³	Lift height (data for 210 in MFH upright)	in(mm)	210 (5334)	210 (5334)
	11		Free Lift	in(mm)	60 (1524)	60 (1524)
	12	Fork Tilt	Back/Forward	degrees	4 / 3	4 / 3
	14	Fork	Std. Fork Size (T x W x L)	in(mm)	1.75 x 4 x 42 (44 x 102 x 1067)	1.75 x 4 x 42 (44 x 102 x 1067)
	15	Overall Dimensions	Length to Fork Face	in(mm)	51.1 (1298)	61.0 (1550)
	16		Overall Length, less forks	in(mm)	75.9 (1928)	81.8 (2078)
			Outrigger ID/OD	in(mm)	See Outrigger Dimensions Chart	See Outrigger Dimensions Chart
			Frame Width	in(mm)	40.25 (1022)	40.25 (1022)
	17		Height, Upright Lowered	in(mm)	95 (2413)	95 (2413)
	18		Height, Upright Extended	in(mm)	258 (6553)	258 (6553)
	19	Turning Radius		in(mm)	69.7 (1770)	76.14 (1934)
	22	Right Angle Stack Aisle ⁴	48 in x 40 in pallet	in(mm)	98.2 (2494)	106 (2692)
	Battery Compartment	W x L x H	in(mm)	38.75 x 18.5 x 32 (984 x 470 x 813)	38.75 x 13.85 x 32(984 x 470 x 813)	
Performance	23	Stability	According to ANSI		Yes	Yes
	24	Speeds	Travel Speed, Max w/ Load	mph(kph)	6.5 (10.5)	6.5 (10.5)
	25		Travel Speed, Max w/o Load	mph(kph)	7.1 (11.4)	7.1 (11.4)
	26		Lift Speed, with Load ⁵	fpm(ms)	72 (.37)	82 (.42)
	27		Lift Speed, without Load ⁵	fpm(ms)	108 (.55)	108 (.55)
	28		Lower Speed, with Load	fpm(ms)	80 (.41)	77 (.39)
	29		Lower Speed, without Load	fpm(ms)	90 (.46)	90 (.46)
Weights	34	Service weight	Including battery, less load	lbs(kg)	8329 (3781)	8708 (3953)
	35	Axle loading	With Load, Front	lbs(kg)	8442 (3833)	6882 (3124)
	36		With Load, Rear	lbs(kg)	4387 (1992)	4826 (2191)
	37		W/O Load, Front	lbs(kg)	3259 (1480)	3427 (1556)
	38		W/O Load, Rear	lbs(kg)	5070 (2302)	5281 (2398)
Chassis	39	Tires/Wheels	Number, Front/Rear		4 / 2	4 / 2
	40		Size, Load Wheels	in(mm)	(4) 5 x 3.76 urethane (127 x 96)	(4) 5 x 3.76 urethane(127 x 96)
			Size, Rear Drive/Steer	in(mm)	13.0 x 5.5 urethane (330 x 140)	13.0 x 5.5 urethane (330 x 140)
			Size, Rear Caster	in(mm)	8 x 4 urethane (203 x 102)	8 x 4 urethane (203 x 102)
	41	Wheelbase		in(mm)	61.7 (1567)	65.75 (1670)
	44	Ground Clearance	With 5.0 diameter load wheels	in(mm)	1.75 (44)	1.75 (44)
	46	Service Brake	Type		Drum and Shoe	Drum and Shoe
	47	Parking Brake	Type		Automatic, Spring Applied	Automatic, Spring Applied
	Steering	Type		Hydraulic Assist, variable	Hydraulic Assist, variable	
Drive Line	48	Battery	Type		Lead Acid	Lead Acid
			Capacity (6 hr rate) maximum	kWh	37.6	37.6
			Weight, minimum	lbs(kg)	2175 (987)	2175 (987)
	49	Motors, Controls	Drive Motor, diameter	in(mm)	6.7 (170)	6.7 (170)
			Hydraulic Motor, diameter	in(mm)	8.0 (203)	8.0 (203)
			Steer/Auxiliary Motor, diameter	in(mm)	6.4 (163)	6.4 (163)
			Drive Motor control	Type	Transistor, infinite	Transistor, infinite
			Speed control	Type	Solid state	Solid state
			Hydraulic Motor control	Type	Contactactor	Contactactor
		Steer/Auxiliary Motor control	Type	Transistor, infinite	Transistor, infinite	

- Notes:**
- 1 Specifications are for tandem 5 in (127 mm) diameter x 3.76 in (96mm) wide load wheels. Single 10.5 in (267 mm) diameter x 4.5 in (114 mm) load wheels and tandem 5 in (127 mm) diameter x 3.01 in (76 mm) wheels are also available.
 - 2 Specifications are given for truck with 210 in (5334 mm) MFH upright, and 42 in (1067 mm) outrigger I.D. and 37 in (940 mm) sidershifter (deduct 50 lbs. (23 kg) for weight less sidershifter). Battery compartment dimensions as noted.
 - 3 See Upright Table. Contact Clark Representative for additional lift heights.
 - 4 Right angle stacking aisle for pallet size shown. See "General Data" section for right angle stack aisle with other pallet sizes.
 - 5 High speed lift is standard on NPR 22 and 15D with 18.5 in (470 mm) and 21.0 in (533 mm) battery compartments; lift speeds will reduce when 16.13 in (409.7 mm) compartment is used.

General Information	1	Manufacturer		Clark	Clark	
	2	Model	Manufacturer's Designation	NSR22	NSR25	
	3	Load Capacity		lbs(kg)	4500 (2000)	5000 (2275)
	4	Load Center	Fork Face to Load CG	in(mm)	24 (600)	24 (600)
	5	Power Unit	Type		24 volt 36 volt	36 volt
	6	Operator Type			Rider Straddle	Rider Straddle
	7	Tire Type			Solid	Solid
	8	Wheels (x=driven)	Front/Rear		4/2 (1x)	4/2 (1x)
Basic Dimensions ^{1,2}	10	Upright ³	Lift height (data for 210 in MFH upright)	in(mm)	210 (5334)	210 (5334)
	11		Free Lift	in(mm)	60 (1524)	60 (1524)
	12	Fork Tilt	Back/Forward	degrees	4 / 3	4 / 3
	14	Fork	Std. Fork Size (T x W x L)	in(mm)	1.75 x 4 x 42 (44 x 102 x 1067)	1.75 x 4 x 42 (44 x 102 x 1067)
	15	Overall Dimensions	Length to Fork Face	in(mm)	49.3 (1251)	54.1 (1374)
	16		Overall Length, less forks	in(mm)	72.2 (1834)	75.9 (1928)
			Outrigger ID/OD	in(mm)	See Outrigger Dimensions Chart	See Outrigger Dimensions Chart
			Frame Width	in(mm)	40.25 (1022)	40.25 (1022)
	17		Height, Upright Lowered	in(mm)	95 (2413)	95 (2413)
	18		Height, Upright Extended	in(mm)	258 (6553)	258 (6553)
	19	Turning Radius		in(mm)	66.5 (1690)	72.1 (1832)
22	Right Angle Stack Aisle ⁴	48 in x 40 in pallet	in(mm)	93.0 (2362)	98.2 (2494)	
	Battery Compartment	W x L x H	in(mm)	38.75 x 13.88 x 32 (984 x 353 x 813)	38.75 x 18.5 x 32 (984 x 470 x 813)	
Performance	23	Stability	According to ANSI		Yes	Yes
	24	Speeds	Travel Speed, Max w/ Load	mph(kph)	5.7 (9.2) 6.6 (10.6)	6.2 (10.0)
	25		Travel Speed, Max w/o Load	mph(kph)	6.3 (10.1) 7.2 (11.6)	7.1 (11.4)
	26		Lift Speed, with Load ⁵	fpm(ms)	40 (.20) 60 (.30)	70 (.36)
	27		Lift Speed, without Load ⁵	fpm(ms)	65 (.33) 95 (.48)	108 (.55)
	28		Lower Speed, with Load	fpm(ms)	80 (.41)	80 (.41)
	29		Lower Speed, without Load	fpm(ms)	80 (.41)	90 (.46)
Weights	34	Service weight	Including battery, less load	lbs(kg)	6780 (3082)	7879 (3581)
	35	Axle loading	With Load, Front	lbs(kg)	7583 (3447)	8717 (3962)
	36		With Load, Rear	lbs(kg)	3697 (1680)	4162 (1892)
	37		W/O Load, Front	lbs(kg)	2460 (1118)	2962 (1346)
	38		W/O Load, Rear	lbs(kg)	4320 (1964)	4917 (2235)
Chassis	39	Tires/Wheels	Number, Front/Rear		4 / 2	4 / 2
	40		Size, Load Wheels	in(mm)	(4) 5 x 3.76 urethane (127 x 96)	(4) 5 x 3.76 urethane(127 x 96)
			Size, Rear Drive/Steer	in(mm)	13.5 x 5.5 rubber (343 x 140)	13.0 x 5.5 rubber (330 x 140)
			Size, Rear Caster	in(mm)	8 x 4 urethane (203 x 102)	8 x 4 urethane (203 x 102)
	41	Wheelbase		in(mm)	56.1 (1425)	61.8 (1568)
	44	Ground Clearance	With 5.0 diameter load wheels	in(mm)	1.75 (44)	1.75 (44)
	46	Service Brake	Type		Drum and Shoe	Drum and Shoe
	47	Parking Brake	Type		Automatic, Spring Applied	Automatic, Spring Applied
	Steering	Type		Hydraulic Assist, variable	Hydraulic Assist, variable	
Drive Line	48	Battery	Type		Lead Acid	Lead Acid
			Capacity (6 hr rate) maximum	kWh	28.9 27.0	37.6
			Weight, minimum	lbs(kg)	1590 (722)	2175 (987)
	49	Motors, Controls	Drive Motor, diameter	in(mm)	6.7 (170)	6.7 (170)
			Hydraulic Motor, diameter	in(mm)	8.0 (203)	8.0 (203)
			Steer/Auxiliary Motor, diameter	in(mm)	6.4 (163)	6.4 (163)
			Drive Motor control	Type	Transistor, infinite	Transistor, infinite
			Speed control	Type	Solid state	Solid state
			Hydraulic Motor control	Type	Contacto	Contacto
		Steer/Auxiliary Motor control	Type	Transistor, infinite	Transistor, infinite	

Notes:

- Specifications are for tandem 5 in (127 mm) diameter x 3.76 in (96mm) wide load wheels. Single 10.5 in (267 mm) diameter x 4.5 in (114 mm) load wheels and tandem 5 in (127 mm) diameter x 3.01 in (76 mm) wheels are also available.
- Specifications are given for truck with 210 in (5334 mm) MFH upright, and 42 in (1067 mm) outrigger I.D. and 37 in (940 mm) sideshifter (deduct 50 lbs. (23 kg) for weight less sideshifter). Battery compartment dimensions as noted.

- See Upright Table. Contact Clark Representative for additional lift heights.
- Right angle stacking aisle for pallet size shown. See "General Data" section for right angle stack aisle with other pallet sizes.
- High speed lift is standard on NPR 22 and 15D with 18.5 in (470 mm) and 21.0 in (533 mm) battery compartments; lift speeds will reduce when 16.13 in (409.7 mm) compartment is used.

Clark NPR 15D/22 reach trucks and NSR 22/25 straddle trucks are designed to meet the increasing performance and reliability demands of narrow aisle applications. Easy operation with strong and reliable component systems provide high user value. General Electric transistor motor controls operate drive and power steering/reach/tilt and auxiliary functions, which add significantly to battery efficiency, with benefits of fewer parts and built-in diagnostics. Choice of either 24 or 36 volt operation (36 volt only on NPR15D, NPR22 and NSR25) with lift height outrigger configurations and options to suit the application needs of most users.

Operator Comfort/Controls

Stand-up compartment is configured for comfortable operation in forward or reverse, even for large operators. Padded, independently adjustable armrest and backpad enhance operator comfort and accommodate all body types and sizes. Full molded urethane compartment padding and soft touch control handle add to safety and comfort. Forward visibility is excellent with secondary lift cylinders and other upright components located behind upright rails. Operator orientation, facing left of forward, provides for high productivity through reduced operator movement for reverse travel and operator choice of stance.

Left-hand steering control with hydraulic power assist for very low steer effort. Single lever hand control with push buttons provides for operation of travel, lift/lower, reach (NPR), tilt and sideshift (optional) functions. Floor pedal provides emergency braking and parking brake with brake-on in up (normal) position. Depression of the pedal and subsequent release actuates independent brakes in both the drive and caster wheel. Formed wire guard prevents hand movement into the upright. Key switch and battery disconnect on control deck. Standard rear guard legs provide protection from intrusion of objects, such as rack beams, during backing and in tight aisle operations.

Motors/Electrical Controls

Series wound high torque drive and hydraulic pump motors and permanent magnet power steering motor are fan cooled and ventilated, and incorporate Class H insulation. Power steering and drive motors feature GE transistor motor controls. General Electric EV-T15 transistor drive motor control incorporates lift interrupt and diagnostic display with technician 'dial-in' adjustment features. Variable speed transistor motor controls provide extended usage between battery recharging. Low noise power steering motor has idle to full speed operation based on steering demand. A solenoid control card with diagnostic LED displays actuates the hydraulic pump contactor and lift, reach (NPR), tilt and sideshift functions. The single speed hydraulic motor utilizes contactor actuation. A large door at the left side of the truck and easy removal of the top cover provides excellent access to motor and control components.

Drive and Brake Assembly

A single, heavy-cast, rear axle supports the drive and the caster wheel assemblies. The drive assembly rotates on a large bearing for steering control. The drive wheel gears are bathed in lubricating oil. Independent spring-applied, hydraulic-release brake on the drive motor armature and within the hub of the caster wheel provide smooth controlled brake action. Service brakes are fully applied for parking when pedal is released. The axle articulates at its center enabling the truck to negotiate floor irregularities. The entire assembly can be easily removed for service.

Outrigger/Load Wheels

Outriggers and upright are a heavy weldment which is bolted to the frame. Toe boxes are welded to the outrigger. Dual load wheels articulate +/- 1/2 inch for smooth operation over expansion joints and floor irregularities. Load wheel assemblies have pressure lubricant points and feature snap ring retainment. Yellow dichromate finish on load wheel rocker plates prevents corrosion.

Steering

Steering control of the drive wheel assembly is through a mechanical shaft with a hydraulic torque generator. Power steering motor idles at 850 RPM and increases to 2200-2400 RPM with increasing steer demand; reduces noise and energy consumption. Responsive 4.1 turns stop-to-stop with maximum steer tiller effort of 30 inch-lbs. Reverse steer operation is available.

Hydraulics

Separate power steering and main hydraulic pumps increase efficiency, improve performance and reduce noise. Integral pump and motor assemblies are reliable, easily serviced. Nylon sump tank of 8.4 gallon capacity withstands high temperatures, is easily cleaned. Spin-on return line filter, suction strainer and tank breather-filler cap. Two hydraulic test ports enable convenient pressure testing of lift and auxiliary functions. O-ring face seal fittings on high pressure lines are easily serviced and greatly reduce leaks.

Upright/Pantograph Assembly

Clark high-visibility, triple stage uprights feature canted rollers and interlocking rails for maximum strength and rigidity. Lift cylinders have hard industrial chrome plating and urethane seals which provide long seal life. The pantograph mechanism of the NPR is a heavy fabrication with tapered roller bearings at the center pivot and is supported with spherical bushings at the attaching pins. Two standard carriage rollers at the front and rear operate in the upright inner rail and a similar rail attached to the pantograph fork carriage. Fork tilt is provided on both the NPR and NSR by moving the fork heels forward and back with a hydraulic cylinder and lever. The NPR reach function utilizes two cylinders hydraulically supplied through a solenoid valve on the pantograph.

Hydraulic plumbing is internal with 50% fewer fittings than many other designs. Upright control devices include flow limiting valves which prevent rapid carriage descent in the event of a line failure, a lowering control valve which provides productive lowering speeds under varied load conditions; hydraulic cushioning between lift stages and a counterbalance valve that provides smooth operation of tilt and reach functions. Forged forks are shaft mounted with pin type retainers.

Standard Features

Key switch, load backrest extension, electronic horn, rear overhead guard post protection, heavy-duty battery rollers and lift-out battery retainers, lever type battery connect-disconnect. Metal capacity plate, durable Operator Manual attached to truck and highly visible warning and instruction labels. Clark's *Employer's Guide to Material Handling Safety* and a "Safety Starts With You" video are also provided with the truck. Finish is high visibility Clark green with flat black upright and trim.

Available Equipment

Various battery compartment sizes, 4.0 in. articulating and 10.5 in. diameter single load wheels, side shifter, freezer conditioning, reverse steering, safety glass front panel (in lieu of wire mesh), back-up alarm, strobe warning lights, operating lights, and U.L. Classified EE rating.

Notes

Performance may vary +5% and -10% due to motor and system efficiency tolerance. The performance shown represents nominal values which may be obtained under typical operating conditions.

Clark products and specifications are subject to change without notice.

© Clark Material Handling Company 2005.

ANSI/ASME and Insurance Classification

Standard truck meets all applicable mandatory requirements of ASME-B56.1 Safety Standard for Powered Industrial Trucks (latest edition at time of manufacture) and Underwriters Laboratories requirements as to fire and electrical shock hazard for "E" classification. For further information contact a Clark representative.

For Your Safety

- **Keep feet, legs and all parts of body inside operator compartment during normal operation.**
- **Look where you drive. Watch for pedestrians. Allow safe stopping distance. Come to a complete stop before leaving operator compartment. Avoid obstructions, especially to the rear and overhead. Avoid drop offs.**
- **Do not operate this truck unless you are trained and authorized. Read, understand and follow instructions in the operator's manual attached to this truck before starting. Clark dealers have replacement manuals.**
- **Perform daily inspection before operating truck. Never operate a truck in need of repair.**

 **North America CMHC**
Worldwide Headquarters
700 Enterprise Drive
Lexington, KY 40510
866-252-5275
www.clarkmhc.com

your authorized CLARK dealer is: