

POWERWORKERS

**Low Lift Pallet Trucks
Electric 24 Volt**

EWP45

4,500 lbs 2045 kg

EWP45



CLARK®
BUILT TO LAST.®

www.clarkmhc.com

Battery Compartment Dimensions

| | For Battery Tray (Tray Size) | | For Industrial Battery | |
|--------|------------------------------|-----|------------------------|-----|
| | in | mm | in | mm |
| Width | 10.4 | 265 | 29.4 | 747 |
| Length | 7.2 | 185 | 8.8 | 224 |
| Height | 11.8 | 300 | 24.5 | 622 |

Connector: SB175 Red

Lead Position: B15"

Note: Industrial battery requires cover.

Pallet Specifications

| | in | mm |
|-------------------------|-------|----------|
| Type: Double Faced Wood | | |
| Size: Length | 48 | 1220 |
| Width (min-max) | 32-48 | 815-1220 |
| Bottom Board | | |
| Nominal Thickness | 0.75 | 20 |

Available Fork Lengths

| Nominal Length | | Actual Length | |
|----------------|------|---------------|------|
| in | mm | in | mm |
| 48 | 1219 | 47.5 | 1207 |

Notes

Performance may vary +5% or -10% due to motor, tire, drive unit and hydraulic efficiency tolerances and battery weight.

CLARK products and specifications are subject to change without notice.

© CLARK Material Handling Company 2006.

SepEx is a registered trademark of Curtis Controls, Inc.

ANSI/ITSDF and Insurance Classification

Standard truck meets all applicable mandatory requirements of ANSI/ITSDF-B56.1 Safety Standard for Powered Industrial Trucks (latest edition at time of manufacture). For further information contact a CLARK representative.

For Your Safety

- Do not operate motorized hand trucks unless you are trained and authorized. Read and understand the operator's manual before operating.
- Do not operate a damaged or faulty truck. Do not attempt repairs unless you are trained and authorized.
- Keep hands on designated grips and feet away from truck. Do not operate truck with wet or greasy hands or shoes.
- Enter confined areas with load end first. Be very careful when operating in confined areas to avoid being pinned.
- Avoid uneven or slippery surfaces and loose materials.
- Travel slowly and with caution on slopes and do not turn. Always travel with load end down grade.
- Do not load truck over capacity on nameplate. Do not handle unstable loads. Be very careful when handling long, high, or wide loads.
- Do not exceed floor weight limits.

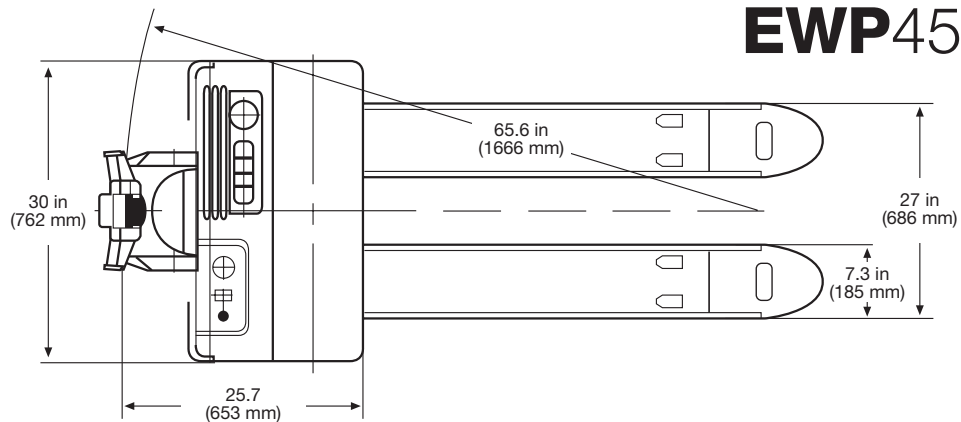
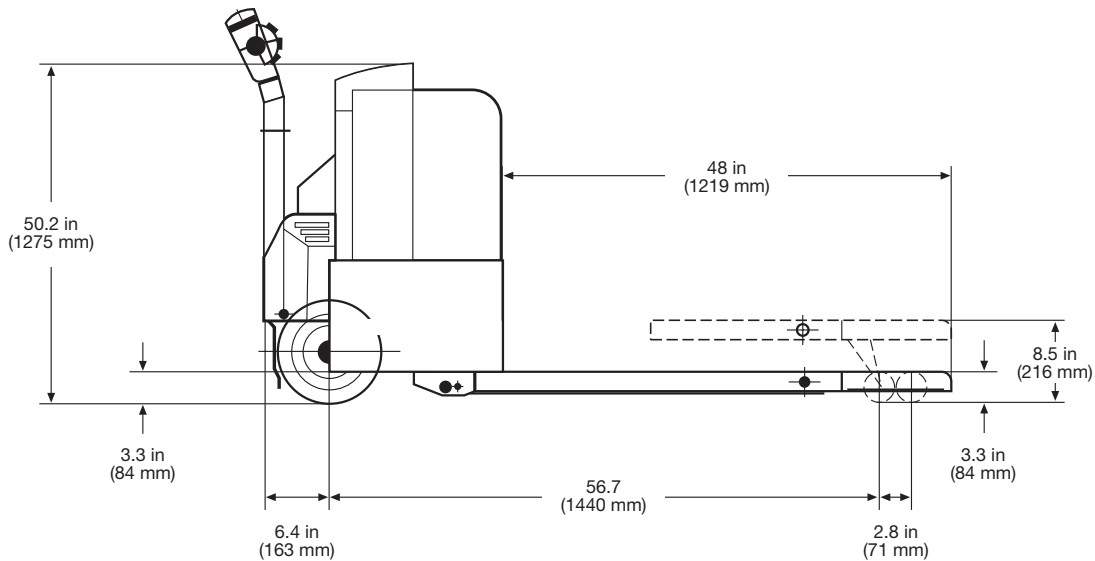

EWP45

| | | | | | | | |
|---------------------|--------------------------------------|----------------------|--------------------------------|---------------------|---------------------------|--------------------------|--|
| General Information | 1 | Manufacturer | | Clark | | | |
| | 2 | Model | Manufacturer's Designation | EWP45 | | | |
| | 3 | Load Capacity | | lbs(kg) | 4500 (2045) | | |
| | 5 | Drive Unit | Electric | | 24 volt | | |
| | 6 | Operator Type | | | Walkie pallet | | |
| | 7 | Tire Type | Front/Rear | | Rubber/polyurethane | | |
| | 8 | Wheels (x=driven) | Front/Rear | | 1x / 2 | | |
| | Basic Dimensions | 9 | Pallet Forks | Maximum fork height | in(mm) | 8.5 (216) | |
| | | Lowered height | | in(mm) | 3.25 (83) | | |
| 14 | | Fork | Width | in(mm) | 7.3 (185) | | |
| | | | Thickness | in(mm) | 2.3 (58) | | |
| | | | Usable length | in(mm) | 47.5 (1207) | | |
| | | | Spread | in(mm) | 27.0 (686) | | |
| 15 | | Overall Dimensions | Length to fork face | in(mm) | 25.7 (653) | | |
| 16 | | | Chassis height, fork lowered | in(mm) | 32.3 (820) | | |
| 19 | Turning Radius | | in(mm) | 65.6 (1666) | | | |
| 22 | Right Angle Stack Aisle ² | Add clearance (6-8") | in(mm) | 78 (1981) | | | |
| Performance | 24 | Travel Speed | Max w/ load | mph(kph) | 2.9 (4.6) | | |
| | 25 | | Max w/o load | mph(kph) | 3.7 (6.0) | | |
| | 26 | Lift Speed | With load | sec | 3.3 | | |
| | 27 | | Without load | sec | 4.2 | | |
| | 29 | Lower Speed | With load | sec | 2.7 | | |
| | | | Without load | sec | 3.3 | | |
| Wt | 34 | Service Weight | Without battery | lbs(kg) | 859 (390) | | |
| Chassis | 39 | Tires | Number, front/rear | | 1 / 2 | | |
| | 40 | | Size, front | in | 10.5 x 5 x 6.5 | | |
| | | | Size, rear | in | 3.2 x 4.7 | | |
| | 41 | Wheelbase | Lowered/raised | in(mm) | 59.5 (1511) / 56.7 (1440) | | |
| | 44 | Ground Clearance | Minimum/at center of wheelbase | in(mm) | 1.0 (25.4) | | |
| | 46 | Service Brake | Type | | Drum and Shoe | | |
| | 47 | Parking Brake | Type | | Spring applied | | |
| | Steering | Type | | Pivot arm | | | |
| Drive Line | 48 | Battery | Type | | Lead acid | | |
| | | | Capacity (6 hr. rate) max | kWh | 7.7 | | |
| | | | Weight, min. | lbs(kg) | 200 (91) | | |
| | 49 | Motors, Controls | Drive motor, diameter | in(mm) | 5.3 (135) | | |
| | | | Hydraulic motor, diameter | in(mm) | 4.9 (124) | | |
| | | | Drive motor control | | | Curtis SepEx™ transistor | |
| | | | Forward/reverse contactors | | | No | |
| | | | Speed control | | | Infinitely variable | |
| | Hydraulic motor control | | | Contacto | | | |
| | | | | | | | |
| | | | | | | | |
| | 57 | Hydraulic Pressure | | psi | 2600 | | |

Notes: 1 Specifications are shown for EWP 45 with battery pack.
 2 Dimension shown is for 48L x 40W load, raised position.

CLARK EWP 45 electric low-lift pallet trucks are ideal for moderate duty cycles. Their quiet operation and clean self-contained hydraulic systems make them ideal for most indoor work areas. Their low initial cost, ease of maintenance and 24-volt electrical system make them an economical alternative to hand pallet jacks.

Operator Comfort/Convenience

- **Formed steel handle with closed loop design**
- **All controls at operator's fingertips**
- **International symbols identify functions**
- **Smooth, stepless speed control in forward and reverse**
- **Reversing switch in handle**

The enclosed handle with designed-in hand guards is especially convenient in tight workspaces. It allows control from either side of the truck and provides excellent hand protection. The smooth contours help prevent snagging on clothes, posts, doorways, machinery or adjacent loads.

Direction, speed, lift/lower and horn controls are all located on the handle. Lift, lower and horn are marked with international symbols.

Reversing switch at the end of the handle is spring-loaded and designed to override the directional control, automatically reversing the truck on contact.

The directional control is thumb actuated and designed for left or right hand operation.

Motors

The 24 volt, separately excited (shunt wound) drive motor is 5.3 in. (135 mm) diameter and fan cooled.

Hydraulic motor is 4.9 in. (124 mm) diameter and vertically mounted.

Electrical System

- **Infinitely variable, separately excited transistor drive control**
- **24-volt operation**
- **Utilizes convenient battery pack with built in charger or industrial battery (neither included in truck price)**
- **150 and 200 amp contactors**
- **Easy access for inspection and testing**

The separately excited control allows elimination of the forward and reverse contactors. This control has many features designed to improve productivity and serviceability including: programmable neutral braking, creep and top speeds, variable plugging and diagnostics to facilitate troubleshooting.

Wiring through the handle is contained in a heavy-duty harness designed to last without undue binding, chafing or twisting.

A battery pack is optional and eliminates the need for special charging equipment. It consists of a steel tray that holds four, deep cycle, heavy-duty batteries and a built-in charger. The charger plugs into any grounded 110/120 volt AC outlet for quick, economical recharging of batteries. The steel tray features hinged, swing-out top batteries for easy bottom battery maintenance. Maintenance free battery packs are also available.

- Battery pack provides 3.52 kwh with a 152 amp hour rating (maintenance free battery pack provides 4.6 kwh with 195 amp hour rating) and is equipped with a SB-175 red connector.
- Industrial battery - 12 cell 7 plate, battery provides up to 7.7 kwh. Cover required.

Drive Line

- **Double reduction helical and spur gears**
- **Totally enclosed**
- **Protected location**

Power from the horizontally mounted drive motor is transmitted through 21 to 1 double reduction helical and spur gears to the drive wheel axle. The gears are mounted on ball and tapered roller bearings and operate totally enclosed in a bath of oil. Drive wheel is mounted on a spline type axle and secured with a single, heavy duty lock nut for quick change in the field.

Brakes

- **Double acting**

Brake is actuated by positioning the handle up or down. In either position, the motor shuts off as the brakes are applied. When the handle is released a heavy spring and chain return it to the vertical position which applies the brake for parking. Brake pads are easily adjusting and easily replaced.

Hydraulic System

- **Integral pump and motor**
- **Simple hosing**

Hydraulic pump, motor, fluid reservoir, relief valves and inlet filter are completely integrated, eliminating most of the connections associated with hydraulic fluid leaks. Plumbing consists of a single, non-flexing hose from the pump to the lift cylinder. The cylinder is a single acting, ram type.

Steering

- **Handle rotates drive unit 180°**
- **Design assures positive control**

Long steer handle with low pivot point provides increased leverage to reduce steering effort. Rectangular tubular design prevents handle flexing and improves control.

Frame and Chassis

- **Formed, unitized steel**

Major components of the truck frame are formed steel, resulting in superior strength at reduced weight. Forks are designed for added rigidity to increase service life. Frame provides single point mounting of hydraulic cylinder and drive unit, absorbs stress of lifting/lowering and travel. All exposed surfaces are covered with a durable acrylic paint, free of chromium and lead.

Standard Equipment

Separately excited 24 volt transistor control; rubber drive tire; poly load wheels; poly skid stabilizers; horn; key switch; hour meter; battery discharge indicator; 48 in. x 27 in. (1220 mm x 686 mm) forks. Finish is high-visibility CLARK green and black.

Options

Battery pack ("wet" or maintenance free batteries) with built in charger; spring loaded stability casters; string guard; 48 in. (1219 mm) and 60 in. (1524 mm) high load backrests; tandem load wheels.

 **CLARK Material Handling Company**
N.A. Sales & Marketing Headquarters
700 Enterprise Drive
Lexington, KY 40510
866-252-5275
www.clarkmhc.com

your authorized CLARK dealer is: