

POWERWORKERS

Electric 24 Volt Walkie Straddle

CSM7
CSM10
CSM15

1500 lbs 680 kg
2200 lbs 1000 kg
3000 lbs 1365 kg

CSM7/10/15



CLARK[®]
BUILT TO LAST.[®]

w w w . c l a r k m h c . c o m

Upright Table

	Maximum Fork Height		Overall Height Lowered		Free Lift		Min ID	
	in	mm	in	mm	in	mm	in	mm
CSM7								
52	1320	72	1830	52*	1320	31	790	
72	1830	92	2335	72*	1830	31	790	
90	2285	72	1830	24	610	31	790	
110	2795	82	2080	24	610	31	790	
130	3300	92	2335	24	610	33	840	
150	3810	102	2590	24	610	38	965	

CSM10/15								
	Maximum Fork Height		Overall Height Lowered		Free Lift		Min ID	
	in	mm	in	mm	in	mm	in	mm
52	1320	71.25	1810	52*	1320	31	790	
72	1830	91.25	2315	72*	1830	31	790	
90	2285	65.25	1655	12	305	31	790	
110	2795	75.25	1910	12	305	31	790	
130	3300	85.25	2165	12	305	33	840	
150	3810	95.25	2420	12	305	38	965	

*Without load backrest

Battery Compartment Dimensions

For Industrial Battery					
Width (W)		Length (L)		Height (H)	
in	mm	in	mm	in	mm
9	230	28.6	726	24.6	625

Minimum Right Angle Stack Aisle*

Load Width (W)	Length (L)		
	36/915	42/1067	48/1219
36/915	73/1855	73/1855	73/1855
40/1015	74/1880	74/1880	74/1880
42/1067	75/1905	75/1905	75/1905
48/1219	76/1930	76/1930	76/1930

*Based on 5 in. (127 mm) side clearance.

Performance

Performances are for trucks with 250 lb. (115 kg) industrial battery. Performance may vary +5% or -10% due to motor, tire, drive unit and hydraulic efficiency tolerances and battery weight.

Truck Capacity

Load centers are determined from top and front face of forks. Capacities are based on a 48 in. (1219 mm) cube load configuration with the center of gravity at the center of the cube and standard forks.

Specific capacities are shown on truck nameplates.

Notes

Clark products and specifications are subject to change without notice.

© Clark Material Handling Company 2005.

ANSI/ASME and Insurance Classification

Standard truck meets all applicable mandatory requirements of ASME-B56.1 Safety Standard for Powered Industrial Trucks. For further information contact a Clark representative.

For Your Safety

- Do not operate motorized hand trucks unless you are trained and authorized. Read and understand the operator's manual before operating.
- Do not operate a damaged or faulty truck. Do not attempt repairs unless you are trained and authorized.
- Keep hands on designated grips and feet away from truck. Do not operate truck with wet or greasy hands or shoes.
- Enter confined areas with load end first. Be very careful when operating in confined areas to avoid being pinned.
- Avoid uneven or slippery surfaces and loose materials.
- Travel slowly and with caution on slopes and do not turn. Always travel with load end down grade.
- Do not load truck over capacity on nameplate. Do not handle unstable loads. Be very careful when handling long, high, or wide loads.
- Do not exceed floor weight limits.
- Do not climb or ride on mast or forks.
- Do not allow anyone to stand under raised forks.

Contact your Clark dealer for operator training information.

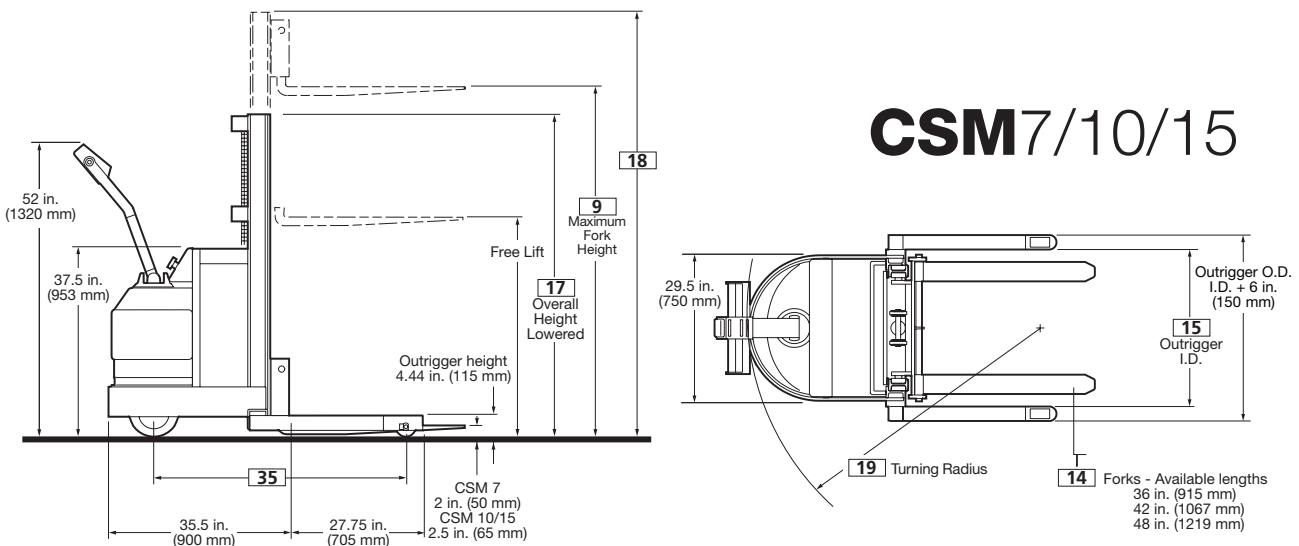

General Information	1	Manufacturer		Clark	Clark	Clark	
	2	Model	Manufacturer's Designation	CSM 7	CSM 10	CSM 15	
	3	Load capacity	lbs(kg)	1,500 (680)	2,200 (1000)	3,000 (1365)	
	4	Load center	Fork face to load CG	in(mm)	24 (600)	24 (600)	24 (600)
	5	Drive Unit	Type	24-volt	24-volt	24-volt	
	6	Operator Type		Hand, pedestrian	Hand, pedestrian	Hand, pedestrian	
	7	Tire Type		Poly / rubber	Poly / rubber	Poly / rubber	
	8	Wheels (x=driven)	Front / rear	2 / 1x	2 / 1x	2 / 1x	
Dimensions	9	Upright	Maximum fork height, full capacity	in(mm)	150 (3810)	150 (3810)	150 (3810)
	10		Lift height	in(mm)	110 (2795)	110 (2795)	110 (2795)
	14	Forks	Standard fork size (TxWxL)	in(mm)	1.5x4x36 (38x102x914)	1.5x4x36 (38x102x914)	1.5x4x36 (38x102x914)
	15	Overall dimensions	Length to fork face	in(mm)	35.5 (900)	35.5 (900)	35.5 (900)
			Outrigger I.D., adjustable	in(mm)	41 to 50 (1040 to 1270)	41 to 50 (1040 to 1270)	41 to 50 (1040 to 1270)
	16		Width	in(mm)	I.D. + 6 (152)	I.D. + 6 (152)	I.D. + 6 (152)
	17		Height, upright lowered	in(mm)	82 (2083)	75.25 (1911)	75.25 (1911)
	18		Height, upright extended	in(mm)	128.75 (3270)	128.75 (3270)	128.75 (3270)
	19	Turning Radius		in(mm)	60.5 (1530)	60.5 (1530)	60.5 (1530)
	22	Right angle stack aisle			See chart	See chart	See chart
Performance ²	23	Stability	According to ASME		Yes	Yes	Yes
	24	Travel Speeds	With load	mph(kph)	2.9 (4.6)	2.6 (4.2)	2.5 (4.1)
			Without load	mph(kph)	3.1 (5.0)	3.1 (5.0)	3.1 (5.0)
	26	Lift speeds	With load	fpm(ms)	22 (.11)	16 (.08)	15 (.08)
			Without load	fpm(ms)	35 (.18)	25 (.13)	23 (.12)
		Lower Speed	With load	fpm(ms)	42 (.21)	37 (.19)	36 (.18)
Without load			fpm(ms)	22 (.11)	19 (.10)	15 (.08)	
Wt	34	Service Weight	Including battery pack	lbs(kg)	1,475 (670)	1,700 (773)	1,720 (782)
Chassis	39	Tires	Number, front/rear		2 (1)	2 (1)	2 (1)
	40		Size, front	in(mm)	4x2 (100x50)	4x2 (100x50)	4x2 (100x50)
			Size, rear	in(mm)	10x4 (255x100)	10x4 (255x100)	10x4 (255x100)
	41	Wheelbase		in(mm)	51.5 (1310)	51.5 (1310)	51.5 (1310)
	42	Track	Center of tires	in(mm)	I.D. + 3 (75)	I.D. + 3 (75)	I.D. + 3 (75)
	44	Ground Clearance	Minimum, with load	in(mm)	1.25 (32)	1.25 (32)	1.25 (32)
	46	Service Brake	Type		Wet disc	Wet disc	Wet disc
47	Parking Brake	Type		Spring applied	Spring applied	Spring applied	
Drive Line	48	Battery	Type		Lead acid	Lead acid	Lead acid
			Capacity (6 hr. rate) max.	kWh	6.6	6.6	6.6
	49	Motors, Controls	Drive motor, dia.	in(mm)	6 (152)	6 (152)	6 (152)
			Hydraulic motor, dia.	in(mm)	4.75 (121)	4.75 (121)	4.75 (121)
			Drive motor control		Solid state	Solid state	Solid state
			Speed control		Infinitely variable	Infinitely variable	Infinitely variable
		Hydraulic motor control		Solenoid	Solenoid	Solenoid	

Notes: 1 Specifications are shown for CSM with standard battery pack and 110" (2795 mm) upright.

2 Travel and lift speeds are nominal. Individual unit performance may vary ±10% due to motor and system tolerances.

The Clark CSM walkie straddle trucks are well suited to storeroom and warehouse areas. The CSM is capable of operating in narrow aisles and its low cost and reliability make it an ideal supplement to rider type equipment.

Control Handle

- Ergonomic design with dual forward/reverse travel controls for thumb or twist operation
- Reversing switch at the end of the handle is spring loaded and designed to override the directional control, automatically reversing the truck on contact
- Brake is actuated by positioning the handle up or down and is automatically applied when handle is released. When the brake is activated, power to the drive unit is cut off

Electrical System

- 24 volt
- Key switch
- Emergency power disconnect button
- Fused drive and control circuits
- High torque drive motor is series wound, fan cooled and has class "H" insulation for maximum protection from heat damage
- Heavy duty motor contactors with replaceable tips

Drive Line

- Sealed gear reducer/brake system with internal multi-disc brakes in oil bath eliminates conventional brake problems such as adjustments, drum and/or shoe replacement
- All gear and brake components protected from exposure to moisture and dirt, packaging, strapping, etc
- All gears are precision ground helical type
- Drive axle mounted on precision-tapered roller bearings

Solid State Speed Controller

- Solid state speed controller with solid state throttle mechanism
- Smooth, stepless acceleration
- Controller programmable to allow custom speed and acceleration settings
- Allows battery efficiency and usage to increase by up to 50% over resistor-controlled units
- Smooth, controlled plugging
- Diagnostic test and fault information

Hydraulic System

- Lifting and lowering functions feature "soft start - soft stop" electro-hydraulic acceleration and deceleration valving.
- Adjustable lowering valve allows loaded and unloaded lowering speed adjustments (pre-set at factory).
- In-line oil filter
- Heavy duty motor, gear pump, check and relief valve
- Overload pressure relief valve protects system from pressure overload and bypasses oil to reservoir when system reaches maximum pressure.
- Piston style lift cylinder includes micro-finished surface and high quality polyurethane seals.

Chassis/Outriggers

- Outriggers adjustable from 41" (1040 mm) to 50" (1270 mm) with guarded tips to protect load wheels
- Standard underclearance of 1.25" (32 mm)

Upright, Forks and Carriage

- Standard shaft-mounted forged fork, length 36" (915mm)
- Optional lengths 42" and 48" (1070 and 1220 mm)
- CSM 10/15 mast of I-beam design (nested on telescopic models) with high quality ball bearing rollers and carriage side thrust rollers
- CSM 7 supplied with channel beam mast
- Lateral thrust carriage rollers reduce effects of off-center loading
- Twin double strand leaf style lifting chain
- Safety screening protects operator from lifting mechanisms and provides maintenance free visibility

Wheels and Tires

- Press-on 10" x 4", (255 x 100mm) white non-marking drive tire, taper-mounted hub design for fast easy servicing.
- Poly load wheels 4" x 2" (100 x 50mm) with precision sealed ball bearings

Batteries

- 170 AH rating, (4-12 volt 85 AH, minimum maintenance deep cycle batteries) with removable tray
- Battery compartment accepts industrial batteries to 275 AH.

Battery Charger

- 115 volt, single phase, 60 hz, 15 amp onboard charger with overload protection
- Direct wired to batteries for error free charging
- Charger is fully automatic, starting when plugged into a 115/1/60 outlet and stopping when batteries are fully charged.

Available Equipment

- Load backrest
- Hour meter
- Hour meter/discharge indicator
- Hour meter/discharge indicator/lift lockout
- Backup alarm
- Flashing light
- UL EE construction

 **North America CMHC**
700 Enterprise Drive
Lexington, KY 40510
866-252-5275
www.clarkmhc.com

your authorized CLARK dealer is: