

IC-PNEUMATIC

GEN 2™ Series

Pneumatic Tire Lift Trucks
LPG/Diesel

C15	3,000 lbs 1500 kg
C18	3,500 lbs 1800 kg
C20s	4,000 lbs 2000 kg

C15/18/20s



CLARK®
BUILT TO LAST.®

w w w . c l a r k m h c . c o m

For corresponding data see Specification Chart.

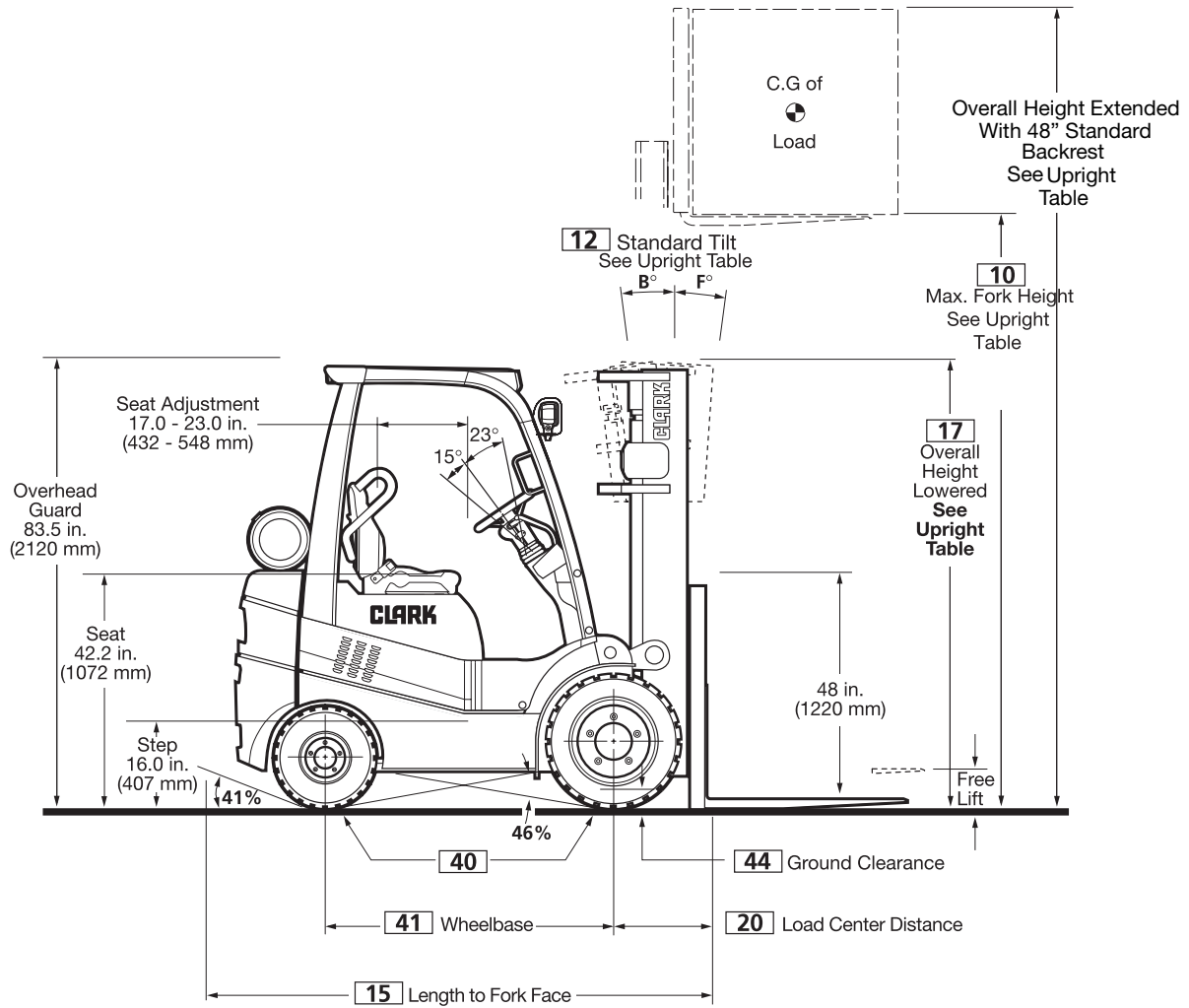

C15/18/20s

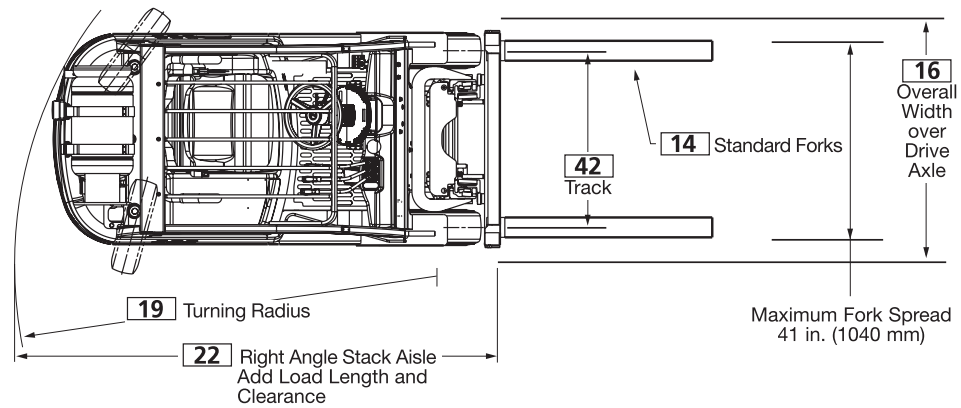

Upright Table

Maximum ¹ Fork Height		Overall Height Lowered		Free Lift ³ w/o LBR		Standard ² Tilt Spec B°/F°
in	mm	in	mm	in	mm	
C15/18/20s Standard						
89	2265	68	1730	4.3	110	8/8
100	2545	74	1870	4.3	110	8/8
110	2795	79	1995	4.3	110	8/8
121	3085	84	2140	4.3	110	8/8
• 129	3285	88	2240	4.3	110	8/8
143	3640	95	2417	4.3	110	8/8
160	4070	106	2690	4.3	110	5/6
172	4365	114	2890	4.3	110	5/6
183	4655	121	3085	4.3	110	5/6
203	5145	134	3415	4.3	110	5/3
C15/18/20s Triple Stage						
156	3970	74	1870	4.9	1238	5/6
171	4345	79	1995	5.4	1363	5/6
• 188	4780	84	2140	5.9	1508	5/6
204	5185	90	2290	6.5	1658	5/3
213	5400	94	2380	6.9	1748	5/3
219	5565	96	2450	7.2	1818	5/3
225	5720	99	2515	7.4	1883	5/3
237	6015	104	2640	7.9	2008	5/3
255	6470	111	2830	8.7	2198	3/0
279	7075	121	3085	9.7	2453	3/0
C15/18/20s Hi-Lo						
115	2925	79	2005	5.5	1389	8/8
• 127	3215	85	2165	6.1	1549	8/8
138	3515	91	2305	6.6	1689	8/8
145	3695	97	2455	7.2	1839	8/8
150	3810	100	2530	7.5	1914	8/8

- Indicates preferred common specification.
- ¹ For overall height raised with load backrest, add 48 in. (1220 mm) to maximum fork height.
- ² Standard tilt shown. Contact Clark representative for information on optional tilt.
- ³ Freelif dimensions shown are without load backrest.

Other uprights available, contact a Clark representative.

Available Equipment

- Auxiliary valves
- Hose adaptations
- Sideshifters
- Hydraulic control options
- Combination stop/tail/backup lights
- Rear work light
- Turn signal lights
- Strobe lights
- Backup alarm
- Mirrors
- Convenience console
- Suspension seat, vinyl and cloth
- Reduced height overhead guard
- U.L. Type LPS construction
- Seat actuated engine shutdown
- Pre-cleaner – overhead guard mounted
- Air cleaner safety element
- Travel Speed
- Bottler's tilt
- Tire Options

Notes

Production engines and driveline components may vary in output and/or efficiency by ±5%. The performance shown represents nominal values which may be obtained under typical operating conditions of a machine.

Clark products and specifications are subject to change without notice.

© Clark Material Handling Company 2004.

ANSI and Insurance Classification

Standard truck meets all applicable mandatory requirements of ANSI-B56.1 Safety Standard for Powered Industrial Trucks and Underwriters Laboratories requirements as to fire hazard only for LP and LPS classifications. For further information contact a Clark representative.

For Your Safety

Before operating a lift truck, an operator must:

- Be trained and authorized
- Read and understand the operator's manual
- Not operate a faulty lift truck
- Not repair a lift truck unless trained and authorized
- Have the overhead guard and load backrest extension in place

During operation, a lift truck operator must:

- Wear a seat belt
- Keep entire body inside truck operator compartment
- Never carry passengers or lift people
- Keep truck away from people and obstructions
- Travel with lift mechanism as low as possible and tilted back

To park a lift truck, an operator must:

- Completely lower forks or attachments
- Shift into neutral
- Turn key off
- Set parking brake

Contact your Clark dealer for operator training information.

SPECIFICATIONS

General Information	1	Manufacturer		Clark	Clark	
	2	Model	Manufacturer's Designation	C15L	C15D	
			in(mm)	STD129 (3285) TSU188 (4780)	STD 129 (3285) TSU 188 (4780)	
	3	Load Capacity	lbs(kg)	3000 (1500)	3000 (1500)	
	4	Load Center	Fork Face to Load CG	in(mm)	24 (500)	24 (500)
	5	Drive Unit	Type	LPG	Diesel	
	6	Operator Type		Rider-Seated	Rider-Seated	
	7	Tire Type		Pneumatic	Pneumatic	
Basic Dimensions	8	Wheels (X=Driven)	Front/Rear	2X/2	2X/2	
	9	Upright	Maximum Fork Height, Full Capacity	in(mm)	188 (4780)	188 (4780)
	10		Lift Height (Preferred Upright)	in(mm)	129 (3285) 188 (4780)	129 (3285) 188 (4780)
	11		Free Lift, Empty	in(mm)	4.3 (110) 59.3 (1508)	4.3 (110) 59.3 (1508)
	12	Upright Tilt	Back/Forward	deg	8/8 5/6	8/8 5/6
	14	Forks	Std. Fork Size (T X W X L)	in(mm)	1.5x4x42 (40x100x1070)	1.5x4x42 (40x100x1070)
	15	Overall Dimensions	Length to Fork Face	in(mm)	86.4 (2196) 86.5 (2199)	86.4 (2196) 86.5 (2199)
	16		Width over Drive Axle	in(mm)	42.1 (1070)	42.1 (1070)
	17		Height, Upright Lowered	in(mm)	88.1 (2240) 84.2 (2140)	88.1 (2240) 84.2 (2140)
			Height, Upright Extended (w/LBR)	in(mm)	169.5 (4305) 236.2 (6000)	169.5 (4305) 236.2 (6000)
	18		Height, Overhead Guard		83.5 (2120)	83.5 (2120)
	19	Turning Radius	Outside	in(mm)	81.6 (2073)	81.6 (2073)
20	Load Center Distance	Center of Drive Axle to Fork Face	in(mm)	15.4 (392) 15.5 (395)	15.4 (392) 15.5 (395)	
22	Right Angle Stack Aisle	Add Load Length and Clearance	in(mm)	97.0 (2465) 97.1 (2468)	97.0 (2465) 97.1 (2468)	
Performance	23	Stability	According to ANSI B56.1	Yes	Yes	
	24	Speeds	Travel Speed, Max w/Load	mph(km/h)	11.2 (18)	10.7 (17.2)
	25		Travel Speed, Max w/o Load	mph(km/h)	11.4 (18.4)	11.1 (17.9)
		Speed on grade, loaded	5% Loaded	mph(km/h)	10.7 (17.3)	10.3 (16.5)
			10% Loaded	mph(km/h)	9.9 (16)	6.3 (10.2)
			15% Loaded	mph(km/h)	5.0 (8.1)	4.4 (7.1)
	26	Lift Speeds, Loaded/Empty		fpm(m/sec)	112/120 (0.57/0.61) 106/114 (0.54/0.58)	112/120 (0.57/0.61) 106/114 (0.54/0.58)
	29	Lower Speeds, Loaded/Empty		fpm(m/sec)	88/82 (0.45/0.42) 84/79 (0.43/0.40)	88/82 (0.45/0.42) 84/79 (0.43/0.40)
	30	Drawbar Pull, Maximum	With Load	lbs(N)	3908 (17387)	3359 (14945)
	31		Without Load	lbs(N)	2425 (10787)	2425 (10787)
32	Gradeability	Maximum With/Without Load	%	45.6 / 21.1	37.5 / 20.9	
Weights	34	Service Weight		lbs(kg)	6140 (2785) 6507 (2952)	6140 (2785) 6507 (2952)
	35	Axle Loading	With Load, Front	lbs(kg)	7960 (3733) 8397 (3933)	7960 (3733) 8397 (3933)
	36		With Load, Rear	lbs(kg)	1180 (552) 1110 (519)	1180 (552) 1110 (519)
	37		W/O Load, Front	lbs(kg)	2815 (1277) 3247 (1473)	2815 (1277) 3247 (1473)
	38		W/O Load, Rear	lbs(kg)	3325 (1508) 3260 (1479)	3325 (1508) 3260 (1479)
	Chassis	39	Tires (Standard)	Number, Front/Rear		2/2
40			Size, Front	in	6.50x10-12PR	6.50x10-12PR
			Size, Rear	in	5.00x8-10PR	5.00x8-10PR
41		Wheelbase		in(mm)	55.1 (1400)	55.1 (1400)
42		Track	Front/Rear	in(mm)	35.0/35.0 (890/890)	35.0/35.0 (890/890)
44		Ground Clearance	Minimum/at Center of Wheelbase	in(mm)	4.72/4.8 (120/124)	4.72/4.8 (120/124)
46		Service Brake	Type		Drum	Drum
47		Parking Brake	Type		Foot	Foot
	Steering	Type		Hydrostatic	Hydrostatic	
Drive Line	49	Engine	Manufacturer/Model		Mitsubishi 4G63	Yanmar 4TNV88
	51		Rated Output	HP(KW)@rpm	39.5 (29) @ 2100	38.6 (28.8) @ 2400
			Torque	lb-ft(Nm)@rpm	101 (137) @ 1800	106 (144) @ 1440
	52		Speed, Max. Governed	rpm	2650	2600
	53		Cylinders/Displacement	cu.in.(liters)	4 / 122 (2.0)	4 / 134 (2.2)
	54	Transmission	Manufacturer/Type, Speeds F/R		Clark/Powershift, 1/1	Clark/Powershift, 1/1
57	Hydraulic Pressure	For Attachments	psi(bar)	2030 (140)	2030 (140)	
58	Sound Level	Avg. at Operator's Ear Per ISO	dB(A)	79	81	

General Information	1	Manufacturer		Clark	Clark	
	2	Model	Manufacturer's Designation	C18L	C18D	
			in(mm)	STD129 (3285) TSU188 (4780)	STD129 (3285) TSU188 (4780)	
	3	Load Capacity	lbs(kg)	3500 (1800)	3500 (1800)	
	4	Load Center	Fork Face to Load CG	in(mm)	24 (500)	24 (500)
	5	Drive Unit	Type	LPG	Diesel	
	6	Operator Type		Rider-Seated	Rider-Seated	
	7	Tire Type		Pneumatic	Pneumatic	
Basic Dimensions	8	Wheels (X=Driven)	Front/Rear	2X/2	2X/2	
	9	Upright	Maximum Fork Height, Full Capacity	in(mm)	188 (4780)	188 (4780)
	10		Lift Height (Preferred Upright)	in(mm)	129 (3285) 188 (4780)	129 (3285) 188 (4780)
	11		Free Lift, Empty	in(mm)	4.3 (110) 59.3 (1508)	4.3 (110) 59.3 (1508)
	12	Upright Tilt	Back/Forward	deg	8/8 5/6	8/8 5/6
	14	Forks	Std. Fork Size (T X W X L)	in(mm)	1.5x4x42 (40x100x1070)	1.5x4x42 (40x100x1070)
	15	Overall Dimensions	Length to Fork Face	in(mm)	88.2 (2241) 88.3 (2244)	88.2 (2241) 88.3 (2244)
	16		Width over Drive Axle	in(mm)	42.1 (1070)	42.1 (1070)
	17		Height, Upright Lowered	in(mm)	88.1 (2240) 84.2 (2140)	88.1 (2240) 84.2 (2140)
			Height, Upright Extended (w/LBR)	in(mm)	169.5 (4305) 236.2 (6000)	169.5 (4305) 236.2 (6000)
	18		Height, Overhead Guard		83.5 (2120)	83.5 (2120)
	19	Turning Radius	Outside	in(mm)	83.5 (2121)	83.5 (2121)
	20	Load Center Distance	Center of Drive Axle to Fork Face	in(mm)	15.4 (392) 15.5 (395)	15.4 (392) 15.5 (395)
	22	Right Angle Stack Aisle	Add Load Length and Clearance	in(mm)	98.9 (2513) 99.0 (2516)	98.9 (2513) 99.0 (2516)
Performance	23	Stability	According to ANSI B56.1	Yes	Yes	
	24	Speeds	Travel Speed, Max w/Load	mph(km/h)	11.1 (17.9)	10.9 (17.6)
	25		Travel Speed, Max w/o Load	mph(km/h)	11.4 (18.4)	11.1 (17.9)
		Speed on grade, loaded	5% Loaded	mph(km/h)	10.6 (17.1)	10.1 (16.3)
			10% Loaded	mph(km/h)	6.3 (10.2)	5.7 (9.1)
			15% Loaded	mph(km/h)	4.3 (6.9)	3.7 (6.0)
	26	Lift Speeds, Loaded/Empty		fpm(m/sec)	110/120 (0.56/0.61) 104/114 (0.53/0.58)	110/120 (0.56/0.61) 104/114 (0.53/0.58)
	29	Lower Speeds, Loaded/Empty		fpm(m/sec)	88/82 (0.45/0.42) 84/79 (0.43/0.40)	88/82 (0.45/0.42) 84/79 (0.43/0.40)
	30	Drawbar Pull, Maximum	With Load	lbs(N)	3924 (17456)	3375 (15014)
	31		Without Load	lbs(N)	2425 (10787)	2425 (10787)
32	Gradeability	Maximum With/Without Load	%	39.4 / 19.8	33.2 / 18.6	
Weights	34	Service Weight	lbs(kg)	6633 (3009) 7001 (3176)	6633 (3009) 7001 (3176)	
	35	Axle Loading	With Load, Front	lbs(kg)	8690 (4166) 9128 (4100)	8690 (4166) 9128 (4100)
	36		With Load, Rear	lbs(kg)	1443 (643) 1373 (573)	1443 (643) 1373 (573)
	37		W/O Load, Front	lbs(kg)	2687 (1219) 3119 (1415)	2687 (1219) 3119 (1415)
	38		W/O Load, Rear	lbs(kg)	3946 (1790) 3882 (1761)	3946 (1790) 3882 (1761)
	Chassis	39	Tires (Standard)	Number, Front/Rear	2/2	2/2
40			Size, Front	in	6.50x10-12PR	6.50x10-12PR
			Size, Rear	in	5.00x8-10PR	5.00x8-10PR
41		Wheelbase		in(mm)	55.1 (1400)	55.1 (1400)
42		Track	Front/Rear	in(mm)	35.0/35.0 (890/890)	35.0/35.0 (890/890)
44		Ground Clearance	Minimum/at Center of Wheelbase	in(mm)	4.72/4.8 (120/124)	4.72/4.8 (120/124)
46		Service Brake	Type		Drum	Drum
47		Parking Brake	Type		Foot	Foot
	Steering	Type		Hydrostatic	Hydrostatic	
Drive Line	49	Engine	Manufacturer/Model		Mitsubishi 4G63	Yanmar 4TNV88
	51		Rated Output	HP(KW)@rpm	39.5 (29) @ 2100	38.6 (28.8) @ 2400
			Torque	lb-ft(Nm)@rpm	101 (137) @ 1800	106 (144) @ 1440
	52		Speed, Max. Governed	rpm	2650	2600
	53		Cylinders/Displacement	cu.in.(liters)	4 / 122 (2.0)	4 / 134 (2.2)
	54	Transmission	Manufacturer/Type, Speeds F/R		Clark/Powershift, 1/1	Clark/Powershift, 1/1
57	Hydraulic Pressure	For Attachments	psi(bar)	2030 (140)	2030 (140)	
58	Sound Level	Avg. at Operator's Ear Per ISO	dB(A)	79	81	

SPECIFICATIONS

General Information	1	Manufacturer		Clark	Clark	
	2	Model	Manufacturer's Designation	C20sL	C20sD	
			in(mm)	STD 129 (3285) TSU 188 (4780)	STD 129 (3285) TSU 188 (4780)	
	3	Load Capacity	lbs(kg)	4000 (2000)	4000 (2000)	
	4	Load Center	Fork Face to Load CG	in(mm)	24 (500)	24 (500)
	5	Drive Unit	Type	LPG	Diesel	
	6	Operator Type		Rider-Seated	Rider-Seated	
	7	Tire Type		Pneumatic	Pneumatic	
Basic Dimensions	8	Wheels (X=Driven)	Front/Rear	2X/2	2X/2	
	9	Upright	Maximum Fork Height, Full Capacity	in(mm)	188 (4780)	188 (4780)
	10		Lift Height (Preferred Upright)	in(mm)	129 (3285) 188 (4780)	129 (3285) 188 (4780)
	11		Free Lift, Empty	in(mm)	4.3 (110) 59.3 (1508)	4.3 (110) 59.3 (1508)
	12	Upright Tilt	Back/Forward	deg	8/8 5/6	8/8 5/6
	14	Forks	Std. Fork Size (T X W X L)	in(mm)	1.5x4x42 (40x100x1070)	1.5x4x42 (40x100x1070)
	15	Overall Dimensions	Length to Fork Face	in(mm)	89.9 (2283) 90.0 (2286)	89.9 (2283) 90.0 (2286)
	16		Width over Drive Axle	in(mm)	42.1 (1070)	42.1 (1070)
	17		Height, Upright Lowered	in(mm)	88.1 (2240) 84.2 (2140)	88.1 (2240) 84.2 (2140)
			Height, Upright Extended (w/LBR)	in(mm)	169.5 (4305) 236.2 (6000)	169.5 (4305) 236.2 (6000)
	18		Height, Overhead Guard		83.5 (2120)	83.5 (2120)
	19	Turning Radius	Outside	in(mm)	84.8 (2154)	84.8 (2154)
20	Load Center Distance	Center of Drive Axle to Fork Face	in(mm)	15.4 (392) 15.5 (395)	15.4 (392) 15.5 (395)	
22	Right Angle Stack Aisle	Add Load Length and Clearance	in(mm)	100.2 (2546) 100.3 (2549)	100.2 (2546) 100.3 (2549)	
Performance	23	Stability	According to ANSI B56.1	Yes	Yes	
	24	Speeds	Travel Speed, Max w/Load	mph(km/h)	11.1 (17.9)	10.8 (17.4)
	25		Travel Speed, Max w/o Load	mph(km/h)	11.4 (18.4)	11.2 (18.1)
		Speed on grade, loaded	5% Loaded	mph(km/h)	10.6(17)	9.9 (16.0)
			10% Loaded	mph(km/h)	6.0 (9.6)	5.4 (8.7)
			15% Loaded	mph(km/h)	4.0 (6.4)	3.5 (5.6)
	26	Lift Speeds, Loaded/Empty		fpm(m/sec)	106/120 (0.54/0.61) 100/114 (0.51/0.58)	106/120 (0.54/0.61) 100/114 (0.51/0.58)
	29	Lower Speeds, Loaded/Empty		fpm(m/sec)	88/82 (0.45/0.42) 84/79 (0.43/0.40)	88/82 (0.45/0.42) 84/79 (0.43/0.40)
	30	Drawbar Pull, Maximum	With Load	lbs(N)	3935 (17505)	3390 (15083)
	31		Without Load	lbs(N)	2204 (9807)	2204 (9807)
32	Gradeability	Maximum With/Without Load	%	37.0 / 17.1	31.3 / 17.1	
Weights	34	Service Weight		lbs(kg)	6957 (3156) 7325 (3323)	6957 (3156) 7325 (3323)
	35	Axle Loading	With Load, Front	lbs(kg)	9458 (4449) 9890 (4210)	9458 (4449) 9890 (4210)
	36		With Load, Rear	lbs(kg)	1499 (707) 1435 (610)	1499 (707) 1435 (610)
	37		W/O Load, Front	lbs(kg)	2590 (1175) 3022 (1371)	2590 (1175) 3022 (1371)
	38		W/O Load, Rear	lbs(kg)	4367 (1981) 4303 (1952)	4367 (1981) 4303 (1952)
	Chassis	39	Tires (Standard)	Number, Front/Rear		2/2
40			Size, Front	in	6.50x10-12PR	6.50x10-12PR
			Size, Rear	in	5.00x8-10PR	5.00x8-10PR
41		Wheelbase		in(mm)	55.1 (1400)	55.1 (1400)
42		Track	Front/Rear	in(mm)	35.0/35.0 (890/890)	35.0/35.0 (890/890)
44		Ground Clearance	Minimum/at Center of Wheelbase	in(mm)	4.72/4.8 (120/124)	4.72/4.8 (120/124)
46		Service Brake	Type		Drum	Drum
47		Parking Brake	Type		Foot	Foot
Drive Line		Steering	Type		Hydrostatic	Hydrostatic
	49	Engine	Manufacturer/Model		Mitsubishi 4G63	Yanmar 4TNV88
	51		Rated Output	HP(KW)@rpm	39.5 (29) @ 2100	38.6 (28.8) @ 2400
			Torque	lb-ft(Nm)@rpm	101 (137) @ 1800	106 (144) @ 1440
	52		Speed, Max. Governed	rpm	2650	2600
	53		Cylinders/Displacement	cu.in.(liters)	4 / 122 (2.0)	4 / 134 (2.2)
	54	Transmission	Manufacturer/Type, Speeds F/R		Clark/Powershift, 1/1	Clark/Powershift, 1/1
57	Hydraulic Pressure	For Attachments	psi(bar)	2030 (140)	2030 (140)	
58	Sound Level	Avg. at Operator's Ear Per ISO	dB(A)	79	81	

CLARK GEN2 SERIES pneumatic tire trucks are designed for long life in diverse material handling applications such as bottling, manufacturing, recycling, warehousing and distribution. These LPG and Diesel powered trucks provide very high levels of operator comfort, performance, reliability, ease of service, low noise, and have set the ergonomic standard for operator compartment design in the material handling industry.

Operator Control & Comfort

These trucks feature the well-respected operator compartment design of the Gen2 series, providing a quiet, comfortable and spacious environment for operators of all sizes. The large floor area is free of obstructions, has a thick molded floor mat for comfort and noise abatement and is easily removable with no tools. The large open step area and grab handle on both right and left sides provide convenient entry and exit. Foot controls feature a two-pedal inch-brake system with low height and short travel pedals. Left pedal is for inching and brake operations, right pedal is for service brakes only. Left foot applied parking brake is designed for hand or foot release.

Hydraulic control valve levers are cowl-mounted. Directional control is left hand fingertip operated and electrically actuated. Direction reversals are hydraulically cushioned. The vinyl safety seat with retractable seat belt and lateral restraint is proven effective. Six inches (150 mm) of forward and backward adjustment, and separate back and seat cushions with molded bolsters for comfort. A tilt steering column locks in one of six positions and 38° total travel. The small diameter, thick section steering wheel is easily operated with one hand, and positioned slightly left of operator center for comfortable and productive operation with the left hand, while allowing right hand operation of the hydraulic levers. Clamshell hood, direct acting latch and gas strut allow easy access for daily inspections.

Instrument Panel

The instrument panel features a full LED/digital display with visual and audible engine monitoring warnings. Functions being monitored include water temperature, engine oil pressure, transmission oil temperature, alternator charge, low LPG fuel and maintenance timer. The state-of-the-art instrument panel incorporates many protection devices for the drive train and electrical system. An automatic engine shutdown system continuously monitors engine oil pressure, engine coolant temperature and transmission oil temperature. Also included is a digital hour meter and neutral start switch. There are warning prompts for the seat belt, parking brake, ignition key, headlights and service engine light. The panel incorporates a diagnostic system to assist with fuel system maintenance and fault indication for the electrical system.

Engine

Featuring a Mitsubishi model 4G63, 2.0 liter (122 c.i.) 4-cylinder overhead cam engine with internal dynamic balancers for reduced vibration and an EPA 2004 compliant LPG fuel system with diagnostics. Camshaft and balancers are cog belt driven. Cast iron deep skirt block with aluminum cylinder head, 5-main bearing crankshaft, hydraulic valve lifters and electronic ignition reduce maintenance requirements. This engine is well known for low maintenance and long service life.

An optional Yanmar model 4TNV88, 2.2 liter (134 c.i.) 4 cylinder Diesel engine with direct injection is also available. Vertical exhaust is standard on Diesel. 2004 EPA compliant, not U.L. listed.

Engine Accessories/Capacities

Trucks are 12-volt negative ground incorporating heavy-duty starter with anti-restart system and 50 amp alternator with integral regulator on LPG and 40 amp on Diesel. Battery is rated at 430 CCA at 0°F (-18°C) on LPG and 630 CCA at 0°F (-18°C) on Diesel. Clean air is achieved by a high capacity air cleaner with raised air inlet. An automatic dirt ejector and air restriction indicator provide extended service life. An optional supplemental safety element and pre-cleaner can easily be added without other changes. Electrical relays and automotive type blade fuses are conveniently located in a covered cowl mounted fuse panel. Moisture resistant electrical connectors and fusible links are located outside the main harness for ease of access. Air and oil filters are easily accessible for service and located to prevent spillage. The hydraulic sump breather remotely

located to prevent spillage. All fluid level checks are easy to access. Crankcase capacity with filter is 4.0 qts. (3.8L) on LPG, 6.1 qts. (5.8L) on Diesel. The LPG tank bracket with double straps is designed for 33.5 lb (15.2 kg) tanks. Diesel fuel tank capacity is 11.1 gal. (42 L).

Transaxle

Featuring a Clark Model TA-12 single-speed, full reversing, powershift transaxle. This rugged and proven Clark transaxle is an integral unit with high ratio, industrial torque converter, full-floating drive axles and drum/shoe brakes. Equipped with electrically controlled directional control, fully modulated clutch packs and precise inching control system. Test ports, fluid check and full-flow oil filter are easily accessible. An integral oil cooler is located in the open core radiator.

Brakes

Self-energizing, hydraulic-actuated drum and shoe type service brakes. Two-pedal system with integral inching and brake pedal on left side and service brake pedal on the right. Heavy cast iron brake shoes, backing plates and drums with openings for lining inspection and adjustment. All components are asbestos-free. The brakes are accessed by removing the wheel hub, axle shaft and brake drum. The left foot parking brake pedal actuates service brakes at both drive wheels, with electric transmission interrupt and fingertip release. The transmission is disengaged when the parking brake is applied.

Hydraulics

A single gear driven pump provides fluid for hydraulic functions and steering. The priority-demand steering system conserves energy by supplying hydraulic fluid on demand-only basis. The hydraulic tank is integral with the truck frame with an in-tank screen, and the in-tank return line filter is easily serviced without spill. A quick-connect pressure port allows convenient pressure checks. All pressure fittings use O-ring face seals for positive sealing. Sump tank capacity is 9.0 gal. (34 L).

Steering

Steering is full hydrostatic with tilt wheel, utilizing a compact axle beam and integral double-acting steer cylinder. High strength spindle assemblies incorporate kingpins and double metal sealed bearings to provide rugged, easily serviced assemblies. The steering linkage uses spherical bearings, double shear link pins and grease fittings. Rubber isolation mounts support the axle, absorb shock and reduce noise.

Upright

Clark designed high visibility uprights are available as standard, Hi-Lo and triple stage in a wide range of lift heights. Upright rails are all-roller operation with canted rollers to accept both normal and side-thrust loads. The ITA Class II fork carriage includes six main rollers and additional side thrust rollers. The load backrest provides excellent visibility. Hydraulic cushioning between stages aids in smooth, quiet operation. Self-lubricating trunnion bushings and simplified roller access improve serviceability. A hydraulic tilt lock valve to prevent cavitation; integral flow limiting valves prevent rapid carriage descent in the event of a line failure; and lowering control valves allow faster lowering speeds when empty or with light loads. Tilt cylinders incorporate self-aligning spherical bushings at both ends for extended seal life. Optional hose adaptations provide optimum visibility through the upright.

Additional Features

Single auxiliary valve, two headlights mounted on the overhead guard, and a 48" high load backrest. The auxiliary hydraulic flow can be easily adjusted at the main valve to suit various attachments. With the one-piece hood and quickly removable floorplate, all routine maintenance checkpoints can be easily accessed. An open-core radiator with integral transmission oil cooler is standard. An automatic engine shutdown system protects driveline components. Color is Clark Green with non-glare matte black trim and white wheels. Tow pin is located in the counterweight. The operator manual is permanently attached in the back of the safety seat.

North America CMHC
Worldwide Headquarters
700 Enterprise Drive
Lexington, KY 40510
866-252-5275
www.clarkmhc.com

C15/18/20s Specification Sheet
59-894-0328 Printed in USA CCI0205

your authorized CLARK dealer is: